



The 320/ 150 has been designed for inline, beside the press and offline granulating and recycling.

The large throat to narrow chassis relationship allows for installations in existing work areas. The large throat opening and powerful design means that the 320/150 granulator offers a performance which is second to none.

Easily manoeuvred due to its wheels, this machine is designed for ease of use and fast, simple cleaning.

CONSISTENT PERFORMER

The scissor cut knives found in the 320/150 granulator are manufactured from hardened steel, featuring adjustable rotor knives for a constant cutting circle and to allow re-sharpening time and time again. Knives are pre-set off the machine

As with all Blackfriars granulator machines, this unit has been designed with durability and reliability in mind.

- Minimal floor space
- Portable
- Large throat
- Scissor cut knives
- Blade re-grinding service available
- Constant cutting circle
- Minimal dust
- Low-noise
- Low energy consumption
- Easy access for cleaning
- No tools required for access

SAFETY

The whole machine is fully interlocked, yet readily accessible.

SPARES & ACCESSORIES

Blackfriars offer a comprehensive range of OEM granulator blades, spares and accessories for our granulator machines and systems.

BLADE SHARPENING

As a member of the Fernite Group of companies we also offer the #1 granulator blade re-sharpening service in the whole of the UK.



OPTIONS

- Sound Deadening
- Pneumatic Extraction
- Airfall De-Dusting
- Conveyor Feed
- Robot Feed
- Nip Roll Feed
- Extrusion Feed
- Hot Melt
- Temperature Sensing

CONTACT

To place an order or discuss your project requirements, please get in touch.

Tel: +44 (0)114 244 0527
Email: enquiries@fernite.co.uk

Our office is open from:

8.30am - 5.00pm Mon-Thurs 8.30am - 3:45pm Fridays

Closed Saturday / Sunday

Model	320/150
Throat Size (mm)	320 x 150
No. of Rotor Knives	6 3xRH-3xLH
No. of Stator Knives	1
Rotor Diameter (mm)	150
Motor range (kW)	4 / 5.5 / 7.5
Output in Kg / Hr with 9mm Screen	70 - 120
Dimensions in mm (L x W x H)	818 x 615 x 1454
Machine Weight (kg)	450

www.blackfriars.com



Blackfriars is a trading style of Fernite of Sheffield Ltd
1 Orgreave Road, S13 9LQ



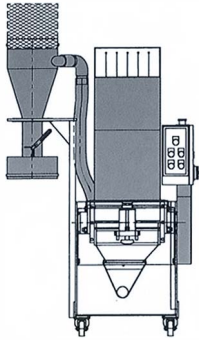

Basic Machine with Granule Discharge to Bin

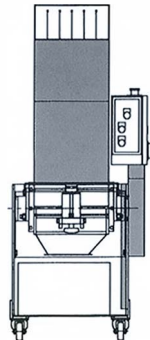

Basic Machine with Pneumatic Air-Veyor.

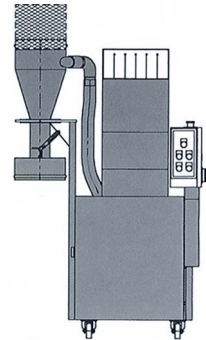

Machine with Noise Suppression and Pneumatic Air-Veyor.

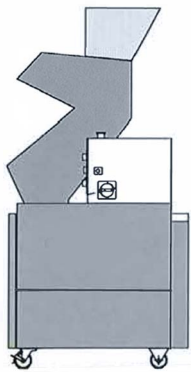

Adaptor for Rigid Profile

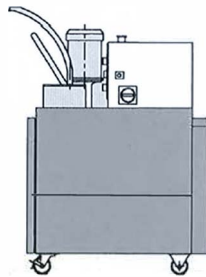

Adaptor for Robot and Rear Conveyor Feed

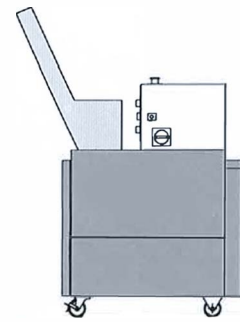

Pinch Roll Feed System

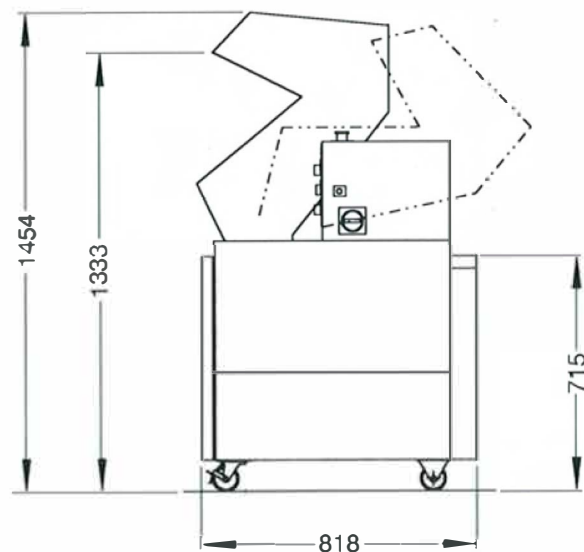
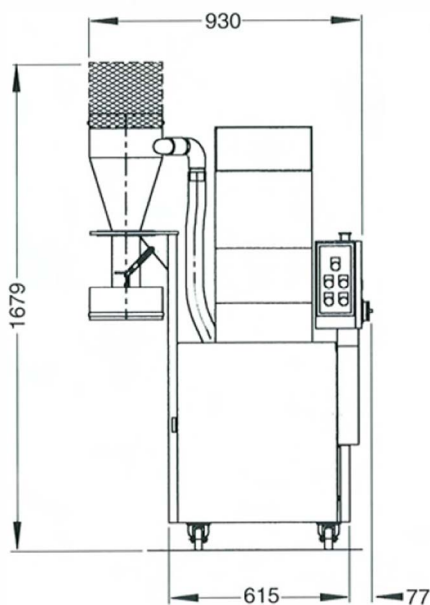

www.blackfriars.com



Blackfriars is a trading style of Fernite of Sheffield Ltd
1 Orgrave Road, S13 9LQ

